

CALI 16 - 180

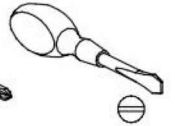

Nr	D[mm]	S[mm]	G[mm]	
1	2040	400	32	1
2	2040	400	32	1
3	1873	1000	16	1
4	1873	400	32	1
5	1807	252	16	1
6	1021	1863	2,5	2
7	1000	80	32	2

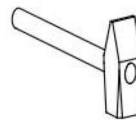
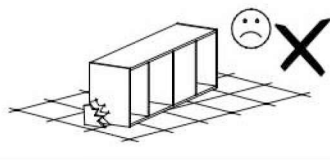
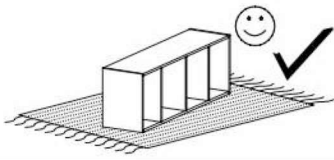
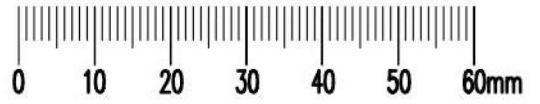
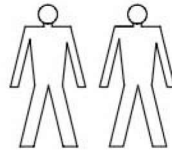
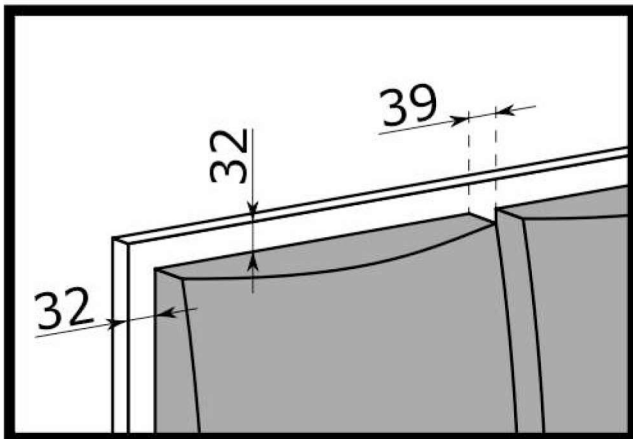
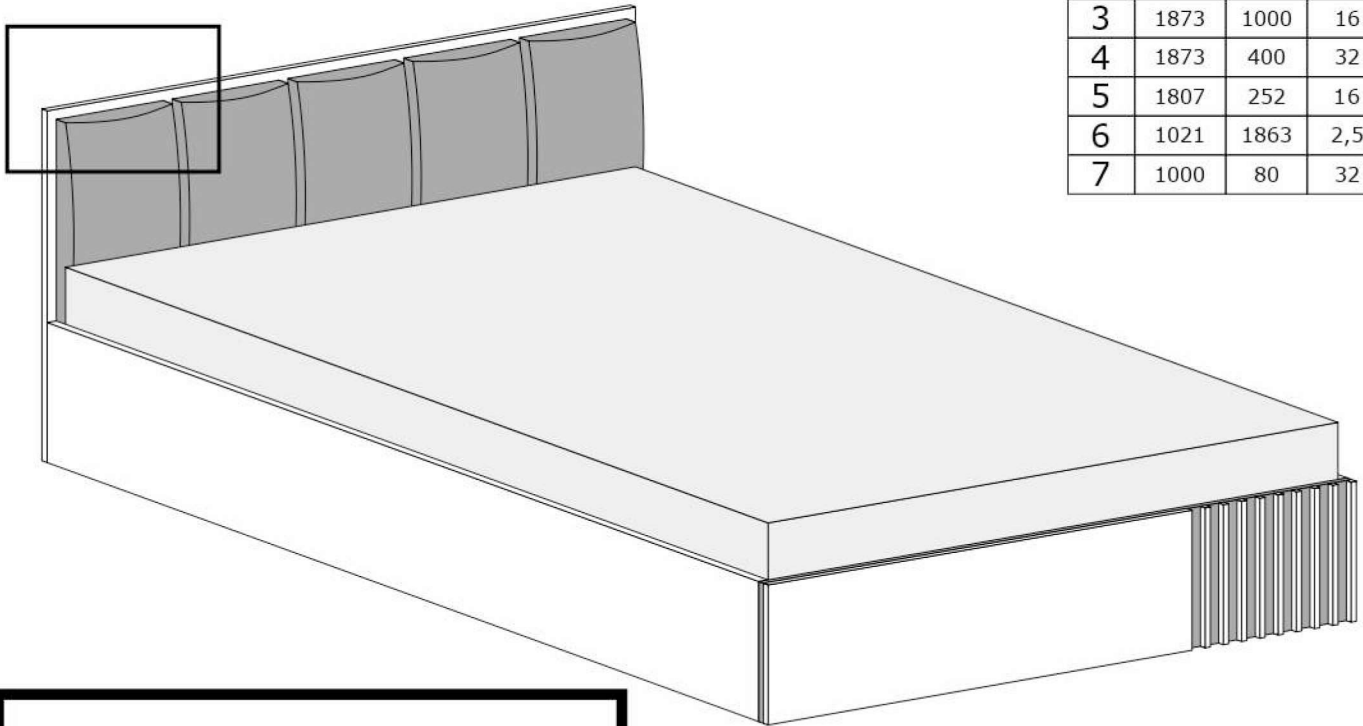

<p>A - 8 St.</p>	<p>B - 4 St.</p>	<p>X1 - 20 St.</p>	<p>Y1 - 4 St.</p>	<p>Y2 - 16 St. 3,5x16 mm</p>
<p>C - 4 St.</p>	<p>D - 12 St.</p>	<p>F - 16 St.</p>	<p>G - 4 St. 6x70 mm</p>	<p>H - 4 St.</p>
<p>I - 10 St. 6x30 mm</p>	<p>K - 1 St.</p>	<p>L - 20 St. 3,9x30 mm</p>	<p>M - 8 St. 3,5x60 mm</p>	<p>S - 1 St.</p>

III

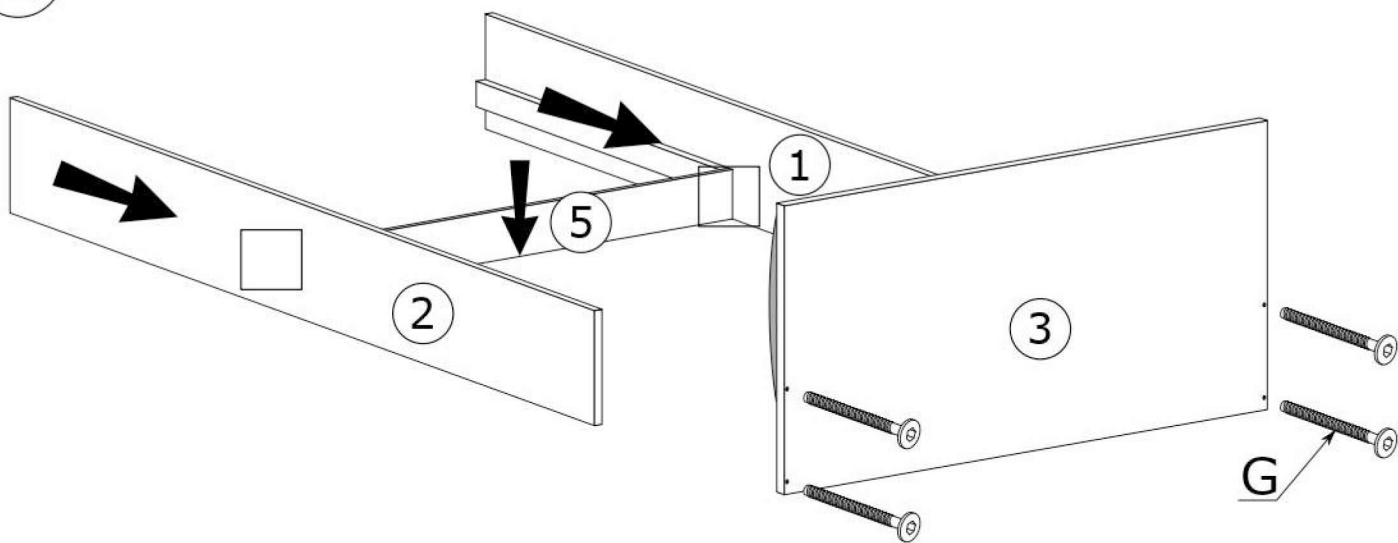

IV

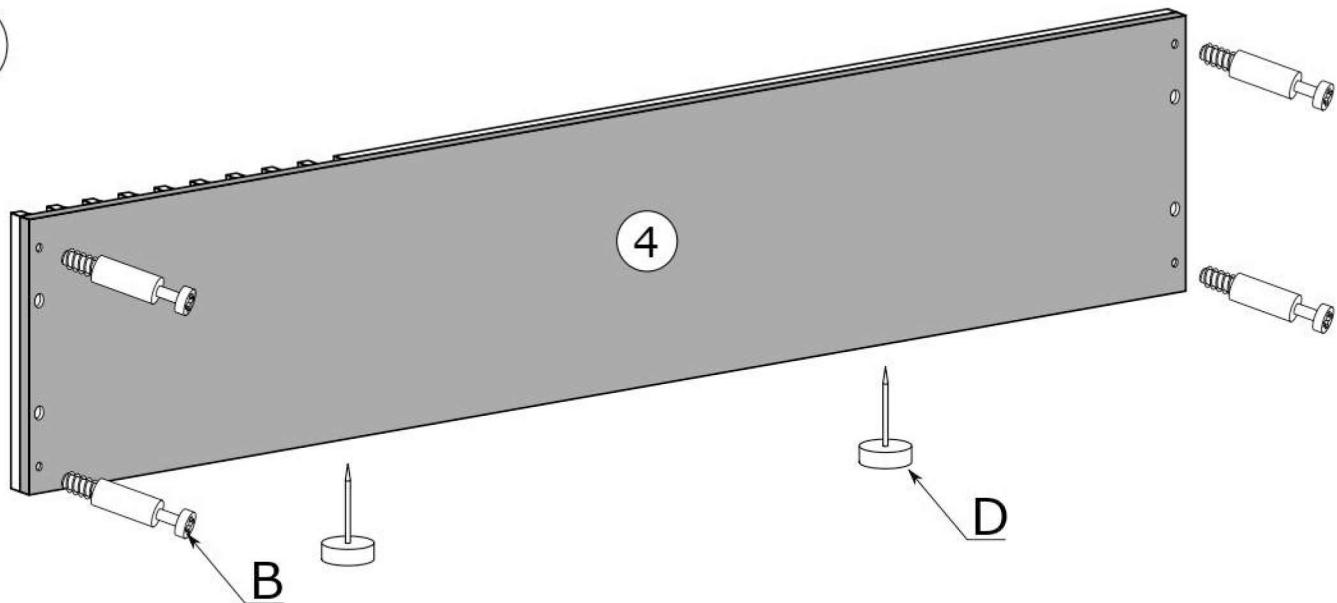

V

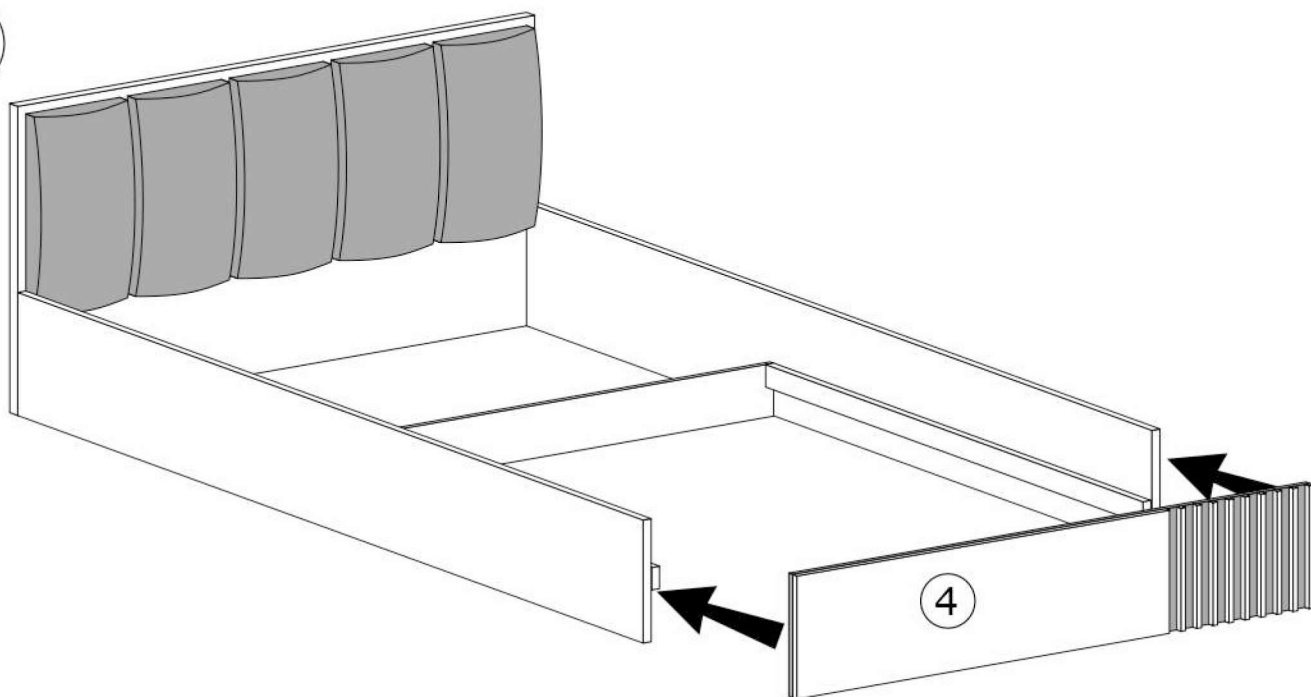

VI

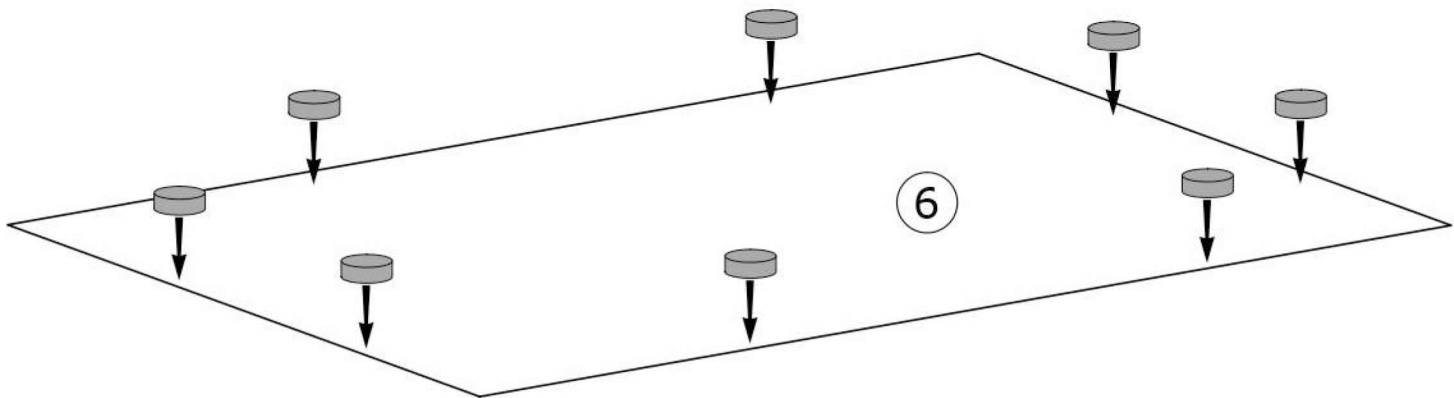
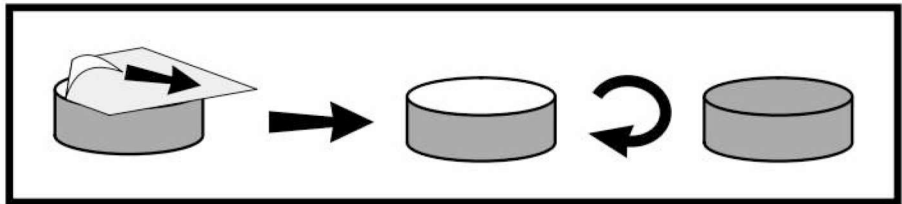

VII

